

TANKO® RPB35 (Rotating Pipe Ball)

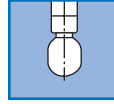
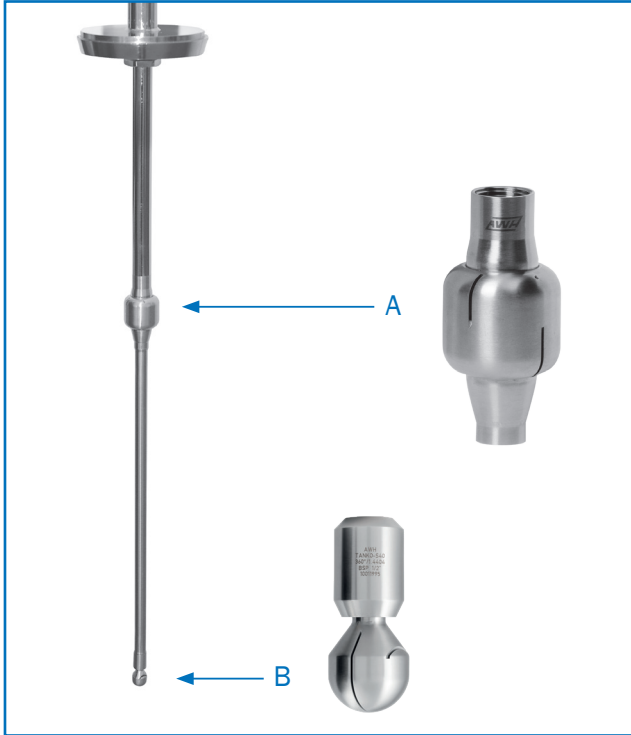

360°

An effective system for reducing spray shadows! A connection fitting and surge sources (TANKO® S) installed at different heights in a downpipe reduce the spray shadows to a minimum.

A "with DP rinsing" RPB variant reinforced with connection/downpipe cleaning is also available in addition to the 360° standard version.

Further spray angles and product variants are available on request.
DP rinsing = Downpipe rinsing upwards

Configuration example:
 Downpipe with TANKO® RPB35 (A) and TANKO® S20 360° (B)

All consumption specifications are for orientation only.
 The dimensions listed are in mm and are nominal dimensions.

Technical Parameters

Spray angle:	360°
Materials:	1.4404 (316L), 1.4435 (316L), 1.4571 (316Ti), 2.4610 (HC4), 2.4602 (HC22), Ball bearings: 1.4401 (316), plain bearing: PEEK
Connections:	Thread, orbital welding connection acc. DIN 11866
Operating pressure:	max. 3 bar / 43.5 psi *
Working temperature:	Cleaning medium: max. plain bearing 60°C / 140°F (higher on request), ball bearing 140°C / 284°F
Ambient temperature:	Inside the vessel: max. plain bearing 140°C / 284°F, ball bearing 180°C / 365°F
Volume flow rate:	at recommended pressure: 1.2 - 2.5 m ³ /h / 20 - 41.7 l/min / 5.3 - 11 gpm (US) *

Pressure (bar)	Pressure (psi)	DP rinsing PB		DP rinsing BB		without DP rinsing PB		without DP rinsing BB	
		Volume (m ³ /h)	Volume (gpm)	Volume (m ³ /h)	Volume (gpm)	Volume (m ³ /h)	Volume (gpm)	Volume (m ³ /h)	Volume (gpm)
1	14.5	1.3	5.7	1.35	5.9	1.2	5.3	1.25	5.5
1.5	21.8	1.6	7	1.7	7.5	1.5	6.6	1.6	7
2	29	1.9	8.4	2	8.8	1.8	7.9	1.9	8.4
3	43.5			2.5	11				

Bearings: Ball bearing or plain bearing
 BB = ball bearing
 PB = plain bearing

*Depending on model and cleaning medium

Measuring Report

Number of measuring points	Description	Price/EUR
4	Roughness	45.00