

Magnetic Filter



General

Magnetic filters, also known as magnetic separators, are still an important component in production plants in the food industry, as well as in the chemical, beverage, plastics and bulk goods industries, or for lubricants.

Magnetic filters ensure that no magnetic metal particles get into the end product. This preventive measure **prevents production downtimes and recalls**. They therefore contribute to maximizing system availability and product safety.

Contamination occurs time and again, either in the delivered raw product or during further processing in production, for example through shearing blades, rollers, cutters, etc. At such times, the magnetic filter is a safe device and prevents the worst from happening.

AWH always uses **cylindrical neodymium magnets** with a remanence value of 1.2 Tesla in the core of the magnet in all magnetic filter bars. These may be used up to an operating temperature of max. 120 °C. The magnetic filters are encased in a thin sheet metal tube in 1.4404 (316L) in the area in contact with the product. Due to its thin wall thickness, this tube ensures a lower loss of magnetic field strength.

AWH offers suitable magnetic filter solutions for various housings.

Whether as **pump protection in the strainer**, in the **AWH Hygiene Inline housing** or as a police filter in combination with an angle tube strainer. All solutions can also be retrofitted and purchased individually.

Magnetic Filter for Angle Type Strainers



Magnetic filters can be integrated into existing angle type strainer housings without much additional effort. Instead of the threaded tie rod installed in the standard housing, a tie rod with a constant magnetic field is retrofitted. No changes to the production plant or the screen housing are required.

Separation takes place in 2 stages in the filtration direction from the outside to the inside. First, larger particles are retained by the sieve. Finer particles that cannot be retained by the sieve are captured by the internal magnetic rod.

Technical Data Magnetic Filter

Nominal diameter	Article-No.	Quantity og magnets	Weight [kg]
25 - 40	610 290 040 202M	14	1.020
50 - 65	610 290 065 202M	13	1.150
80 - 100	610 290 100 202M	3 x 18	4.750
125 - 150	610 290 150 202M	6 x 27	11.94

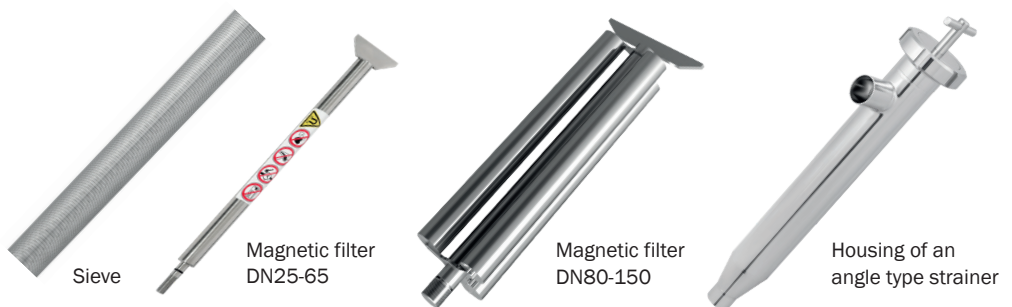

Magnetic Filter for Dirt Traps

AWH also offers a magnetic filter solution for the dirt trap housing. A three-bar magnet with the same magnetic field strength can be inserted into this housing in place of the strainer. This filter is particularly suitable as pump protection and retains smaller particles in particular. The magnetic filter is available for welded, clamp and threaded dirt traps.

Nominal diameter	D1	D2	H1	Description	Article-No.	Weight [kg]
25	25	64	170	Magnetic insert DN25	650 005 302	0.7
40/50	25	91	212	Magnetic insert DN40	650 008 302	1.0
65	3 x 25	106	226	Magnetic insert DN65	650 009 302	2.4
80	3 x 25	119	226	Magnetic insert DN80	650 010 302	2.6
100	3 x 25	155	248	Magnetic insert DN100	650 012 302	4.0

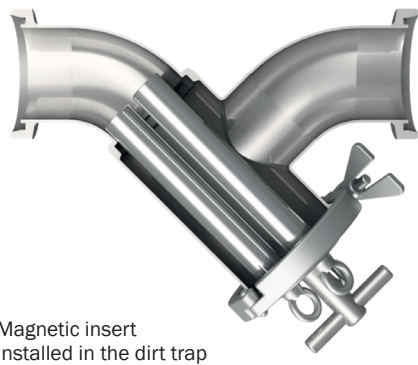

Magnetic insert installed in the dirt trap

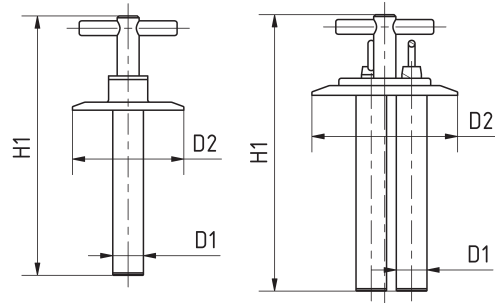

DN25 - DN50

DN65 - DN100

Magnetic Filter for Hygienic Inline-Housing

AWH has developed a three-bar magnet for the hygienic inline housing with type N connection, which can also be used in the sterile area of cosmetics and biopharmaceuticals.

The hygienic inline housing has multiple uses and can also be equipped with sight glasses, lights and sensors thanks to its standardized connection.

Nominal diameter	D1	D2	L	L1	Description	Article-No.	Weight [kg]
65	84	22	141	61	Magnetic insert DN65	630 1300 1065 30	1.09

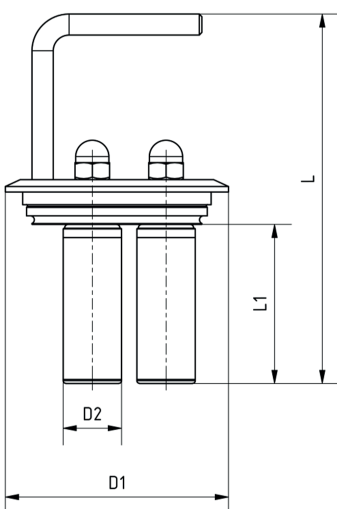

Magnetic insert



Magnetic insert installed in the Hygienic Inline Housing



Armaturenwerk Hötensleben GmbH
 Schulstr. 5-6
 D-39393 Hötensleben

Tel: +49 39405 92-0
 Fax: +49 39405 92-111
 E-Mail: info@awh.eu
 http://www.awh.eu

NEUMO Ehrenberg Group

